

Specification

Lithium Polymer Battery Pack LP804050 2P 4000mAh 3.7V with Protection Circuit Module (PCM)
 This data sheet describes the requirements and properties of lithium polymer rechargeable battery pack manufactured by LiPol Battery Co., Ltd - China

Mechanical Characteristics

- Cell ▶ LP804050 2P
- PCM ▶ Yes
- NTC ▶ No
- Configuration ▶ 1S2P
- Weight ▶ appr.80g

Electrical Specification

- Rated Capacity ▶ 4000mAh min, 4030mAh typ.
- Nominal Voltage ▶ 3.7V
- Wat-Hour Rating ▶ 14.8Wh
- Max. Operating Voltage Range ▶ 2.75V to 4.20V
- Max. Charge Voltage ▶ 4.2V ± 50mV
- Max. Charge Current ▶ 2000mA
- Max. Continuous Discharge Current ▶ 2000mA
- Discharge Cut Off ▶ 2.75V
- Internal Impedance ▶ <120mΩ
- Expected Cycle Life ▶ 500 cycles ≥ 80%
 @ (0.5C/0.5C) @ 23±5°C

Cell Protection

- Overcharge Detection ▶ 4.275 ±50mV (0.7 to 1.3sec. delay, release 4.275V ±50mV)
- Overdischarge Detection ▶ 2.75V ±50mV (14 to 26msec. delay, resume 2.50V ±50mV)
- Overcurrent Detection ▶ 4A to 4.5A (8 to 16msec. delay)

Ambient Conditions

- Charge Temp. Range ▶ 0 to +45°C
- Discharge Temp. Range ▶ -20 to +60°C
- Storage Temp. Range ▶ 1 year at -20 to +30°C >70%
▶ 3 months at -20 to +45°C >70%
▶ 1 month at -20 to +60°C >70%
- Humidity ▶ 65 ±20%RH

Environmental and Safety

Please follow LiPol Handling and Safety Precautions for Lithium Polymer Battery.
 This battery meets the requirements of Battery Directives, and the battery parts are IEC 62133 & RoHS-Compliant. For more safety precautions and performance standards, please go to www.lipolbattery.com/support.html

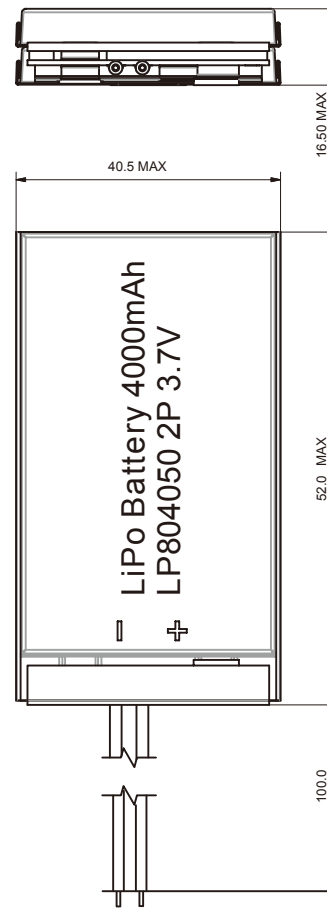
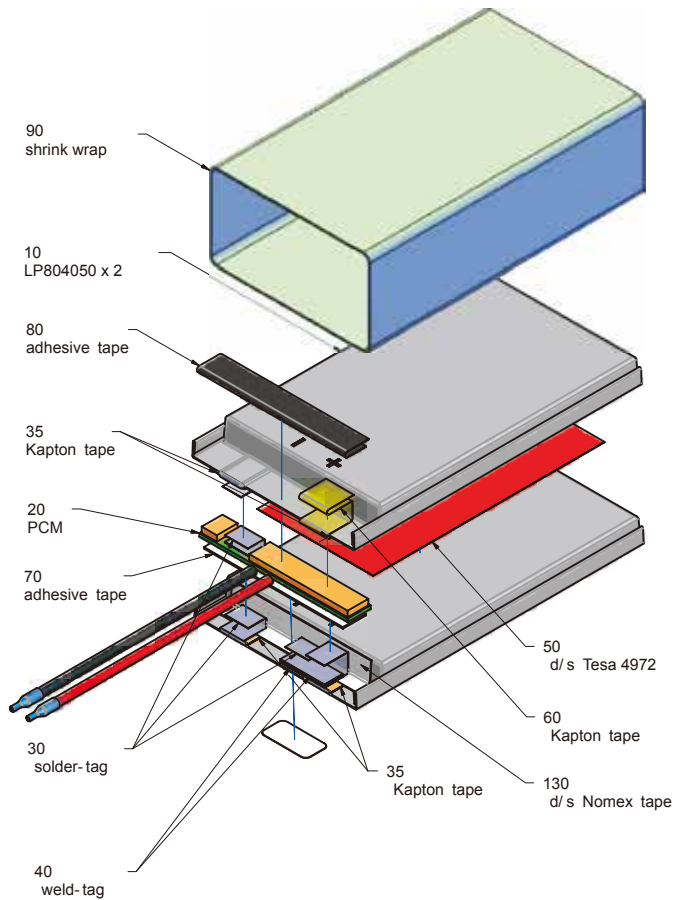

Circuit diagram

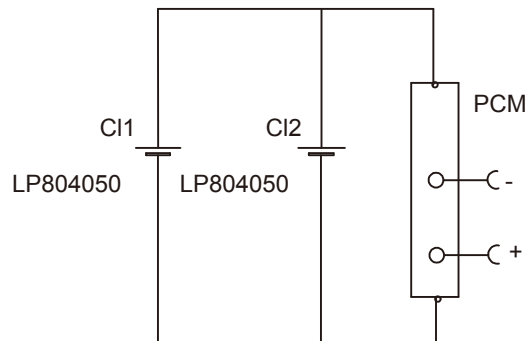

Projection: 	Diese Mae werden besonders gepruft This dimensions are considered inspectable		Material 6645165 6332	
Mae in mm All dimensions in mm	Freimatoleranzen Generaltolerances	Date 23.05.2019	Name Xie Qingfang	LiPol Battery
Als Betriebsgeheimnis anvertraut, alle Rechte vorbehalten.	up to 6 : 0,1 over 6 up to 30 : 0,2	Bearb./Desig. 23.05.2019	Guo Daxia	
Proprietary data, company confidential, all rights reserved.	over 30 up to 100 : 0,3 over 100 : 0,5	Benennung/ Designation LP804050 2P		
		3	Zchg. / Dwg. Nr. FD_2500_30	Index
		www.LiPolBattery.com		support@lipolbattery.com